



Department of Community Development (Updated 2017)

## **Standard Operating Procedures**

For Single-Family Residential Inspections

This guide lists all normally required inspections for single-family residential construction. There may be more or fewer required inspections at the discretion of the Building Official in order to verify code compliance. It is the responsibility of the job superintendent to assure that the project is ready for inspection and accessible to the inspector. The City of Seabrook adheres to and enforces the 2015 International Residential Codes, the 2017 National Electrical Code, and the 2015 International Energy Conservation Code. *Note: This document is not all inclusive.*

### 1. All inspections

- 1.1 Proper location address clearly visible from the street.
- 1.2 City approved plans on site.
- 1.3 Leave correction or approval notice at all inspections.
- 1.4 Verify previous notice on re-inspections.
- 1.5 Verify inspections comments from printout on re-inspections.
- 1.6 Check general cleanliness of job site.
- 1.7 Debris containment provided on site.
- 1.8 Construction barrier on job sites bordering occupied residence.
- 1.9 Keep the streets clear of construction materials and debris.
- 1.10 Proper extension cords are in use.
- 1.11 Water used for construction from hose bibs or fire hydrants shall have an approved back-flow prevention device.
- 1.12 Provide silt fencing at perimeter of construction site, protected construction entrance, and sand bags or other approved storm water protection measure at storm sewer inlets.
- 1.13 Provide a "wash-out" area for concrete.
- 1.14 Provide a minimum of one portable restroom facility on site.

### 2. T-Pole inspection

- 2.1 Pole is secure in ground.
- 2.2 Outlets with GFCI Protection and provided with proper weatherproof covers.
- 2.3 Ground wire secure to ground rod.
- 2.4 Box is weatherproof, in good condition, and displaying location address.

### 3. Ground Plumbing inspection

- 3.1 DWV test: Hydrostatic test with stack 10' above finished floor inside forms, visually check joints for leaks; or provide gauge test to 5 psi inside forms, observe pressure for 15 minutes.
- 3.2 Building drain minimum 12" depth at building exit.
- 3.3 Verify proper pipe joint connection including: de-burring, primer, and glue.
- 3.4 Pipe properly sloped.
- 3.5 Pipe is continuously bedded in solid material (Bank Sand / Select Fill).
- 3.6 Sleeve all plumbing in structural beams with a minimum 24" long SDR pipe min. 1 sizes larger than the pipe being sleeved.

**City of Seabrook**  
**Department of Community Development** (Revised 2017)

4. Water Line inspection

- 4.1 Proper materials and fittings used.
- 4.2 Line is located minimum 5' horizontally from sewer or on shelf 12" above sewer.
- 4.3 Line is continuous bedded in solid material and will have minimum 6" of cover.
- 4.4 Line is air tested to 60 psi minimum or city water is on.

*For Water Tap Inspection Contact (Public Works Department: 281-291-5725)*

5. Sewer Line inspection

- 5.1 Provision is made to allow a minimum of 12" of fill over sewer line.
- 5.2 Sewer is properly sloped and bedded in sand.
- 5.3 Clean out provided at transition from building drain to building sewer (no more than 3' away from foundation), at any change in direction, and sewer runs greater than 100' L.F.
- 5.4 Sewer is tested with water stack 10' above finished floor, outside form.

*For Sewer Tap Inspection Contact (Public Works Department: 281-291-5725)*

6. Piling or Foundation inspection – **Note: Call Drilled Piers in as a partial foundation inspection and coordinate with the building department for an inspection time or have the Engineer of record provide a sealed letter of inspection certifying that "the piers were installed per the engineers design and the approved plans".**

- 6.1 Piling survey to be submitted to office before scheduling a piling inspection (Elevated home only)
- 6.2 Site inspection of pilings to verify placement and compliance with setbacks and easements (elevated home only)
- 6.3 Closed form survey to be submitted to office before scheduling a foundation Inspection (slab on grade only)
- 6.4 Provide a FEMA elevation certificate to office based on building under construction for all new or substantially renovated structure(Prior to scheduling a foundation inspections for Slab on Grade):
  - 6.4.1 For AE and X zones, the top of the bottom floor (including crawlspace or enclosure floor) must be a minimum of 18" above the listed Base Flood Elevation for the project.
  - 6.4.2 For V and VE zones the bottom of lowest horizontal member must be a minimum of 18" above the listed Base Flood Elevation for the project.
- 6.5 Site inspection to verify location of slab make up and compliance with setbacks and easements.
- 6.6 Beam layout, beam sizes, tendon count, corner bars, and reinforcing steel per city approved plans
- 6.7 Pads are firm and even.
- 6.8 Provide string lines to verify slab thickness.
- 6.9 Beams are firm in bottom, no water covering steel or tendons.
- 6.10 No holes in vapor barrier, vapor barrier taped at all seams.
- 6.11 No structural steel in slab shall be supported by steel supports in contact with ground (tape or wrapped steel supports not allowed).
- 6.12 Mastic barrier on all exposed PVC to 4" above finished floor minimum.
- 6.13 Plumbing DWV system shall be tested after installation by water (10-foot head of water on stack) or air (5lbs psi on to of water filled PVC) both test maintained for 15 minutes. Any repairs to PVC must be re-inspected.
- 6.14 Pipes passing under a footing or passing thru a beam shall be sleeved, Min. one pipe sizes larger than the pipe being sleeved.

**City of Seabrook**  
**Department of Community Development** (Revised 2017)

- 6.15 Min. 4" of clearance under any tub bucket, to allow concrete to fill under bucket. Protect / mastic any exposed plumbing pipe under the tub bucket.
- 6.16 The use of 6-inch diameter or larger pipe sleeves thought structural beams will require an engineered detail.

7. Windstorm Inspection

- 7.1 Site inspection of all framing and windstorm strapping prior to installation of exterior sheathing (walls and roof)

8. Cover-up and Frame inspections *Prior to scheduling these inspections:*

- o *Structure must be dried-in: roofing complete, all doors and windows installed sheathing and moisture barrier installed and sealed.*
- o *Plumbing and gas shall have a test on systems.*
- o *Install temporary guard rails at stairs and balconies*

- 8.1 Provide Engineer sealed certification letter to the building department for property under construction verifying that the structure is in compliance with all code requirements for 150 Mph (Ultimate) wind design and is constructed per the engineered design submitted for permitting

- 8.2 Provide a FEMA elevation certificate for Homes elevated on pilings based on building under construction to the building department:

- 8.2.1 For VE zones, the bottom of the lowest horizontal structural member must be above base flood elevation by a minimum of 12".

8.3 WALLS

- 8.3.1 Studs shall be a minimum No. 3, standard or stud grade lumber.

- 8.3.2 The size, height, and spacing of studs shall be in accordance with table R602.3 (with exceptions)

- 8.3.3 Where joists, trusses or rafters are spaced more than 16" on center and the bearing studs are spaced 24" on center, such members shall bear within 5" of studs beneath (with exceptions).

- 8.3.4 Notching of any stud in an exterior wall or bearing partition may be cut or notched to a depth not exceeding 25% of its width. Nonbearing partitions may not exceed 40% of a single stud.

- 8.3.5 Drilling and boring of any stud, the diameter of the resulting hole shall not be more than 60% of the stud's width, the edge of the hole is no more than 5/8 inch to the edge of the stud, and the hole is not located in the same section as a cut or notch. Studs located in exterior walls or bearing partitions drilled over 40% and up to 60% shall be doubled with no more than 2 successive doubled studs bored (with exception).

- 8.3.6 Top plates shall not be less than 2" nominal thickness and have a width at least equal to the width of the stud (with exception).

- 8.3.7 Bottom (sole) plate, studs shall have full bearing on a nominal 2-by or larger plate or sill having a width at least equal to the width of the studs.

- 8.3.8 Drilling and cutting of the top plate by more than 50% of its width shall require a galvanized metal tie to be fastened across and to the plate at each side of the opening with not less than 8 16D nails at each side (with exception).

- 8.3.9 Fire blocking shall be provided to cut off all concealed draft openings (both vertical and horizontal) and to form a barrier between stories and between a top story and roof space.

- 8.3.10 Headers over all openings sized properly.

**City of Seabrook**  
**Department of Community Development** (Revised 2017)

- 8.3.11 Where opening of an operable window is located more than 72" above finish grade or surface below, the lowest part of the clear opening of the window shall be a minimum of 24" above finish floor of the room located (with exception).
- 8.3.12 Glazing requirements for windows shall refer to section R308.

**8.4 CEILING/FLOOR**

- 8.4.1 Ceiling joists sized, oriented, and graded per city-approved plans
- 8.4.2 Habitable rooms, hallways, corridors, bathrooms, toilet rooms, laundry rooms, and basements shall have a ceiling height of not less than 7' measured from finish floor to lowest projection of ceiling (with exceptions).
- 8.4.3 Ends of joist shall not have less than 1.5" of bearing on wood or metal and not less than 3" on masonry or concrete.
- 8.4.4 Joist framing from opposite sides of bearing wall shall lap a minimum of 3" and nailed together with a minimum (3) 10D face nails.
- 8.4.5 Ceiling joist shall be supported by approved framing anchors or on ledger strips not less than nominal 2" x 2".
- 8.4.6 Ceiling joist shall be supported laterally at the ends by full depth solid blocking (minimum 2" nominal thickness), or by attachment to a full-depth header, band, or rim board/joist, or to an adjoining stud or otherwise provided with lateral support to prevent rotation (Rat Run).
  - 8.4.6.1 Ceiling joist exceeding a nominal 2" x 12" shall be supported laterally by solid blocking, diagonal bridging or a continuous 1" x 3" strip nailed across bottom in intervals not exceeding 8'.
  - 8.4.6.2 Drilling and notching of structural ceiling/floor members shall not be cut bored or notched in excess of the limitations allowed.
- 8.4.7 Buildings with combustible ceiling or roof construction shall have an attic access opening (22 x 30) to attic areas that exceed 30 square feet and have a vertical height of 30" or more.

**8.5 ROOF**

- 8.5.1 Rafters shall be framed to ridge board (1 inch minimum) nominal thickness and hip and valley ridges (2 inch minimum) nominal thickness and shall be supported by a brace to a bearing partition to distribute load.
- 8.5.2 Where ceiling joists are not connected at rafters, rafter ties shall be installed to provide a continuous tie, minimum 2 x 4 nominal.
- 8.5.3 Hip and valley ridges that are spliced must be laminated on both sides with 1/2-inch plywood extending a minimum of 18" from both sides of splice.
- 8.5.4 Purlins shall be sized no less than the required size of the rafters they support. Purlins shall be continuous and supported by 2 x 4 braces installed to bearing walls at a slope not less than 45° from horizontal and spaced not more than 4' on center and the un-braced length of braces not to exceed 8'.
- 8.5.5 The ends of rafters and ceiling joist shall have not less than 1-1/2" of bearing on wood/metal and not less than 3" on masonry/concrete.
- 8.5.6 Rafters and ceiling joist exceeding 2 x 10 (nominal dimension) shall be provided with lateral support at points of bearing to prevent rotation.
- 8.5.7 Rafters and ceiling joists exceeding 2 x 12 (nominal dimension) shall be supported laterally by solid blocking, diagonal bridging or continuous 1 x 3 nailed across at intervals not exceeding 8'.
- 8.5.8 All valleys, hip ridges, and braces to be supported with 2 or more studs at load bearing walls (departmental policy).

**City of Seabrook**  
**Department of Community Development** (Revised 2017)

**8.6 STAIRS**

- 8.6.1 Stair minimum width of 36" in clear width at all points above the permitted handrail height and below the required headroom height.
- 8.6.2 The minimum headroom in all parts of the stairway shall not be less than 6' 8".
- 8.6.3 Stair risers 7-3/4" maximum with 3/8 of inch variance over all.
- 8.6.4 Minimum tread depth of 10" with a nosing of no less than 3/4" and not greater than 1 1/4" with 3/8 inch variance over all (with exceptions).
- 8.6.5 Handrails shall be provided on at least one side of each continuous run of treads or flight with 4 or more risers.
- 8.6.6 Handrail height, measured vertically from nosing shall not be less than 34" and no more than 38" (with exceptions).

**8.7 MECHANICAL**

- 8.7.1 Appliances installed in rooms shall be accessed by an opening or door, unobstructed passageway not less than 24" wide, a level service space not less than 30" deep and the height of the appliance.
- 8.7.2 Appliances installed in attics shall be provided with an opening and clear and unobstructed passageway for removal of largest appliance, passageway 24" wide, a level service space 30" deep and 30" wide, with a clear access opening a minimum 20" x 30" (with exceptions).
- 8.7.3 A luminaire shall be located at the required opening controlled by a switch and a receptacle outlet at or near appliance.
- 8.7.4 Pipes installed thru bored holes, notches in studs, joist, and rafters less than 1.5" from nearest edge to be protected with shield plates to extend 2" above bottom plate and 2" below top plate.
- 8.7.5 Foundations and supports for outdoor mechanical systems shall be raised a minimum 3" above finished grade.
- 8.7.6 Secondary A/C drains terminated at an exterior conspicuous point of disposal, or installation for float switch in drain pan wired to disable the mechanical unit in place of a secondary drain line.
- 8.7.7 Condensate drain line size shall be not less than 3/4-inch (internal diameter), shall not be decreased in size from drain to point of disposal and installed at a uniform slope.
- 8.7.8 Primary drain line to be insulated from unit to point of entry at top plate (departmental policy).
- 8.7.9 Mechanical units and ducts properly supported to building structure.
- 8.7.10 Prohibited locations for return air for air heating or cooling systems (with exceptions).
- 8.7.11 Fireplace appliances with class B gas vents installed per manufacturer instructions.
- 8.7.12 Overhead exhaust hoods, a clearance of 24" shall be maintained between the cooking surface and the combustible material or cabinet.
- 8.7.13 Exhaust ducts for clothes dryers shall terminate to outside and not less than 3' in any direction from openings into building.
- 8.7.14 Four (4) inch clothes dryer exhausts ducts shall not exceed 25' with deductions of 2.5' for 45° and 5' for 90° changes of direction (with exceptions). BOOSTER FANS ARE NOT ALLOWED.

**8.8 ELECTRICAL**

- 8.8.1 Wiring is properly imbedded in walls.
- 8.8.2 Minimum wire size of 12 gauge per City ordinance.
- 8.8.3 Aluminum wire is not allowed to be used as any conductor per City ordinance.
- 8.8.4 Outlets shall be installed so that no point measured horizontally along the floor line in any wall space is more than 6'.

**City of Seabrook**  
**Department of Community Development** (Revised 2017)

- 8.8.5 A wall space is considered any space 2' or more in width, including around corners and unbroken along floor line.
  - 8.8.6 Hallways 10' or more in length shall have at least one outlet.
  - 8.8.7 Outlets installed at kitchen counter tops 12" or wider and no point along wall is more than 24" horizontally from an outlet (with exception).
  - 8.8.8 Island and Peninsular counter spaces shall have at least one outlet installed.
  - 8.8.9 Outlets are allowed to be located above, but not more than 20" above countertop.
  - 8.8.10 Outlets at islands are to be located 12" below countertop. Outlets shall not be located below a countertop where the countertop extends more than 6" beyond its base at kitchen and dining rooms.
  - 8.8.11 At least one outlet shall be installed in bathrooms within 36" of the outside edge of each basin (with exception).
  - 8.8.12 Proper box fill (number of conductors and appliances in embedded electrical box).
  - 8.8.13 Where subject to damage, wiring methods thru notched/bored holes less than 1-1/4" from the nearest edge of the stud shall be protected with a nail plate 1/16-inch thick and appropriate length.
  - 8.8.14 All smoke detectors shall be listed in accordance with UL 217 and installed with the provision of this code and the household fire warning equipment provision of NFPA 72.
- 8.9 PLUMBING
- 8.9.1 Water distribution piping shall be tested at 60 psi or on city water pressure, visually check system for leaks.
  - 8.9.2 DWV test: hydrostatic test to minimum 8' above finished floor, visually check joints for leaks; or provide a gauge test to 5 psi, observe pressure for 15 minutes.
  - 8.9.3 All installed shower pans on test for inspection (filled with water 2" at a minimum).
  - 8.9.4 Water distribution piping properly sized, correct material used, joints properly made water portability correctly protected.
  - 8.9.5 Drains properly sized and sloped, correct materials used, fitting properly utilized, joints properly made, traps correctly protected with vent.
  - 8.9.6 Drilling or notching of structural members within allowable limits or correctly repaired.
  - 8.9.7 All piping (other than steel or cast iron) within 1-1/2" of edge of wood members shall be protected with 16 gauge shield plates.
  - 8.9.8 Lead test; check solder content in water distribution piping joints for lead content.
  - 8.9.9 Fixtures provided with adequate space and clearances.
  - 8.9.10 No plumbing vent terminal within 10' of operable windows, doors, or soffit vents unless 2' above opening.
  - 8.9.11 Toilet flanges on wood decking secured with minimum of 4 fasteners.
  - 8.9.12 Plumbing cleanouts provided with proper clearance.
  - 8.9.13 Water heater installed properly; T&P discharge pipe made of correct materials and joints, not trapped, contains no more than (4) 90° fittings and no longer than 30' in developed length unless pipe is upsized (manufacturer); drain pan required where leakage may cause damage with minimum 1" drain line.
- 8.10 GAS
- 8.10.1 Gas test minimum 5 psi on diaphragm gauge
  - 8.10.2 Gas piping proper size, correct pipe material, fittings, and joints; no piping in HVAC ducts or chases, or clothes chutes; no unions, tubing fittings, etc. in concealed locations; piping properly supported; boring and notching in structural members within allowed limits or correctly repaired.

**City of Seabrook**  
**Department of Community Development** (Revised 2017)

- 8.10.3 Gas piping within structural concrete foundations shall be installed inside conduit, sealed where piping enters/exits conduit, and conduit is vented to outside.
- 8.10.4 All gas vents terminated with approved cap the correct distance above roof and away from walls, windows, soffits, etc.; roof penetration properly flashed.

**8.11 CHIMNEYS AND FIREPLACES**

- 8.11.1 Hearth extensions shall extend at least 16" in front and 8" beyond each side of the fire place opening. Where the fire place opening is 6 square feet or larger, the hearth extension shall extend 20" in front and 12" beyond each side of the opening.
- 8.11.2 Fire place clearance of all wood beams, joists, studs and other combustible material shall have a clearance of not less than 2" (with exceptions).
- 8.11.3 All spaces between chimneys and floors and ceilings through which chimneys pass shall be fire blocked with noncombustible material securely fastened in place.
- 8.11.4 Factory-built fire places shall be listed and labeled and shall be installed in accordance with the conditions of the listing (manufacturer).
- 8.11.5 Hearth extensions of approved factory-built fireplaces shall be installed in accordance with the listing of the fireplace.
- 8.11.6 Factory-built chimneys shall be listed and labeled and shall be installed and terminated in accordance with the manufacturer's installation instructions.

**8.12 FIRE BLOCKING**

- 8.12.1 Fire blocking shall be provided to cut off all concealed draft openings (vertical and horizontal) and to form an effective fire barrier between stories, and between a top story and a roof space.
- 8.12.2 Fire blocking shall be provided for chimneys and fireplaces.
- 8.12.3 The integrity of all fire blocks shall be maintained.
- 8.12.4 Interior fire places must be fire blocked at or below the projected ceiling and furr downs within chase with noncombustible material securely fastened in place.
- 8.12.5 Fire blocking material shall consist of nominal lumber, 2 layers of 5/8" OSB, 3/4" plywood, 1/2" sheetrock, or 1/4" hardy plank. Batts and blankets of mineral wool or glass fiber or other approved materials installed and secured in place shall be permitted.

**9. Brick Tie / Lath inspection (separate inspections)**

- 9.1 Ties 16" on center vertically and horizontally (departmental policy 16" O.C. E.W. with exception).
- 9.2 Masonry veneer shall be anchored to the supporting wall with corrosion-resistant metal ties.
- 9.3 Ties shall be placed around all wall openings greater than 16" in either dimension.
- 9.4 A water-resistive barrier shall be applied as a means of draining water to the exterior of the veneer; not less than a 2-inch overlap applied horizontal and a 6-inch overlap applied vertical.
- 9.5 All lath and lath attachments (weep screeds) shall be corrosion-resistant material.
- 9.6 Service entrance conductors entering or on the exterior of building shall be insulated.
- 9.7 Exterior wall penetrations shall be made water tight, sealed, and rodent-proof. All electrical, plumbing, and gas lines penetrating exterior walls shall be insulated and protected from corrosion.

**10. Driveway/Sidewalk/Flatwork inspection(s) (See City detail.)**

- 10.1 No vegetation within formed area.
- 10.2 Level grade properly (4" depth minimum).
- 10.3 Number 6 gauge wire mesh with chairs throughout form.

**City of Seabrook**  
**Department of Community Development** (Revised 2017)

- 10.4 Proper tie in to street per city detail.
  - 10.5 Two hundred (200) square feet maximum without expansion joints.
  - 10.6 Sidewalks, doweled expansion joint 36' Max. and 4' Max. between control joints.
  - 10.7 Rebar splices will overlap 30 times the diameter of rebar spliced.
  - 10.8 Expansion joint provided between structure and outdoor paving (dowels not required).
  - 10.9 Minimum #4 rebar dowels 12" minimum through expansion joints in driveways, #3 rebar minimum at sidewalks and patios (not required into foundations) maximum 24" O.C." or #6 wire mesh.
11. Electrical Meter or Temporary Cut In (TCI) inspection **(TCI form must be received and approved in office prior to inspection request.)**
- 11.1 **An Electrical inspection without an approved TCI form will require that all wiring to be terminated in fixtures, outlets, and switches (no open wiring, electrical system complete).**
  - 11.2 **Aluminum** wire is not allowed to be used as any conductor in the City of Seabrook.
  - 11.3 Grounding electrodes properly connected to service panel.
  - 11.4 Rod and pipe electrodes not less than 8' in length.
  - 11.5 Verify metal water piping is bonded to the service equipment.
  - 11.6 Verify gas system is bonded to the service equipment.
  - 11.7 Main disconnect located at exterior of building next to meter, not higher than 6'-7" above grade.
  - 11.8 Proper meter can per utility provider, meter enclosure is bonded back to service equipment, service panel is weather tight and no slots are left open in panel.
  - 11.9 A minimum clear space is provided at front of the service panel 30" wide and 36" deep.
12. Gas Meter inspection
- 12.1 All gas-fired and vented appliances properly installed and safe to operate.
  - 12.2 Sediment trap installed on furnace and water heaters not equipped with integrated trap.
  - 12.3 Gas-fired water heater relief valve(s) and discharge piping complete.
  - 12.4 Gas test minimum 5 psi on diaphragm gauge; observe 15 minutes for pressure drop.
  - 12.5 All gas piping complete to equipment shut-off valve which is within 6' maximum of appliance and readily accessible; gas line is connected to appliance or line is capped past valve if appliance will be added later (clothes dryer, range, grill); sediment trap correctly installed between shut-off valve and water heater or furnace
  - 12.6 All gas vents properly installed and (manufacturer); supported; terminated with approved cap the correct distance above roof and away from walls, windows, soffits, etc.; roof penetration properly flashed {G2426.7.5}; sloped minimum 1/4" per foot; horizontal run of vent connector does not exceed vertical rise from draft hood to terminal; proper clearance to combustibles maintained (manufacturer).
  - 12.7 Clearances around appliances maintained (manufacturer).
  - 12.8 Appliances provided with correct combustion and ventilation air
  - 12.9 Appliances in attic provided with minimum 30"x 22" opening, a clear and unobstructed minimum 24" wide and 30" high continuous path that is no longer than 20' from opening to appliance and terminating with a minimum 30" x 30" platform in front of the service side of appliance.
  - 12.10 Disappearing attic Ladder installed with adequate support "min. of (8) 16D nails or (4) 1/2" x 4" long lag screws.
  - 12.11 Clearance around gas meter from ignition sources maintained per utility provider requirements minimum 3'-0".
  - 12.12 Gas piping system bonded back to service panel per electrical code.



**City of Seabrook**  
**Department of Community Development** (Revised 2017)

13. Final inspection(s) (building, mechanical, electrical, plumbing, gas, and development inspections are scheduled at the same time) *Prior to scheduling these inspections:*
- Provide a copy of the final survey
  - Provide final FEMA Elevation Certificate based on “Finished Construction.” Include final photos
  - Provide Final Energy Certification Letter from third party certifier stating that the project meets all requirements of the 2009 IECC.

13.1 BUILDING

- 13.1.1 Permanent address in place.
- 13.1.2 Portable restrooms and silk screen fencing removed from site.
- 13.1.3 Windstorm panels and connections located on site.
- 13.1.4 Weep holes open at bottom of brick walls and over all lintels, maximum spacing of 33”.
- 13.1.5 Tendon ends grouted, nails removed (post-tension slab only).
- 13.1.6 Lot graded for proper drainage, minimum of two rows of sod at street for storm water protection.
- 13.1.7 Doors operate properly and without the use of keys.
- 13.1.8 Hand rails (34” to 38” height) and guardrails (36” minimum height) with guards spaced no greater than 4” apart.
- 13.1.9 All penetrations at exterior of structure are properly sealed.
- 13.1.10 All construction debris, port-a-cans, roll-off / dumpster removed from site.

13.2 MECHANICAL

- 13.2.1 Outdoor condenser is secured against uplift in 12m Mph. Wind Event, and breaker properly sized per manufacturer’s specifications.
- 13.2.2 Proper access path to and service area in front of mechanical equipment.
- 13.2.3 All penetrations and exhaust vents sealed properly.
- 13.2.4 Central air conditioning is operable.
- 13.2.5 Heater/furnace flue pipe is properly installed per manufacturer’s specifications.
- 13.2.6 Heating and cooling equipment and ducts are properly supported by building structure.
- 13.2.7 Manufactured fire places functioning properly.
- 13.2.8 Pan under cooling coil is installed with proper slope to drain line.

13.3 ELECTRICAL

- 13.3.1 Main disconnect located at exterior next to meter, at a maximum height of 6’ 7” above grade.
- 13.3.2 All circuits and main labeled in service panel and face plate secured in place.
- 13.3.3 T-Pole disconnected and removed from site.
- 13.3.4 All exterior receptacles shall have ground-fault circuit-interrupter protection.
- 13.3.5 Operable switch, lights, and plugs in all habitable rooms.
- 13.3.6 All light fixtures installed interior and exterior and sealed properly, no blank plates at boxes, install “key list” fixtures.
- 13.3.7 Check for operation of dishwasher, food waste grinder, cook top, cook top exhaust/microwave, and oven.
- 13.3.8 Required GFCI protected receptacles function properly, reset on same floor, outside resets in garage.
- 13.3.9 Kitchen receptacles that serve countertop surfaces shall have ground-fault circuit-interrupter protection.
- 13.3.10 Spa tub disconnect in proper location – 5’ minimum from tub.
- 13.3.11 Check all outlets, switches, and appliances for proper operation.

**City of Seabrook**  
**Department of Community Development** (Revised 2017)

13.4 PLUMBING

- 13.4.1 Plumbing fixtures set and connected correctly to supply and drain.
- 13.4.2 Fixtures provided with adequate space and clearances.
- 13.4.3 Hot water provided and is on the left-hand side of fitting/fixture.
- 13.4.4 Pipes above grade or in attic protected from freezing.
- 13.4.5 All required valves accessible: main shutoff, water heater supply, and water closet supply.
- 13.4.6 Clean outs installed correctly with proper access and spacing.
- 13.4.7 All potable water outlets properly protected from backflow/back siphonage; hose bibs have permanently attached vacuum breakers.
- 13.4.8 Water heater temperature and pressure relief valve(s) operate freely without leaks.

**Figures for boring and notching of structural members** (IRC 2009)

**City of Seabrook**  
**Department of Community Development (Revised 2017)**

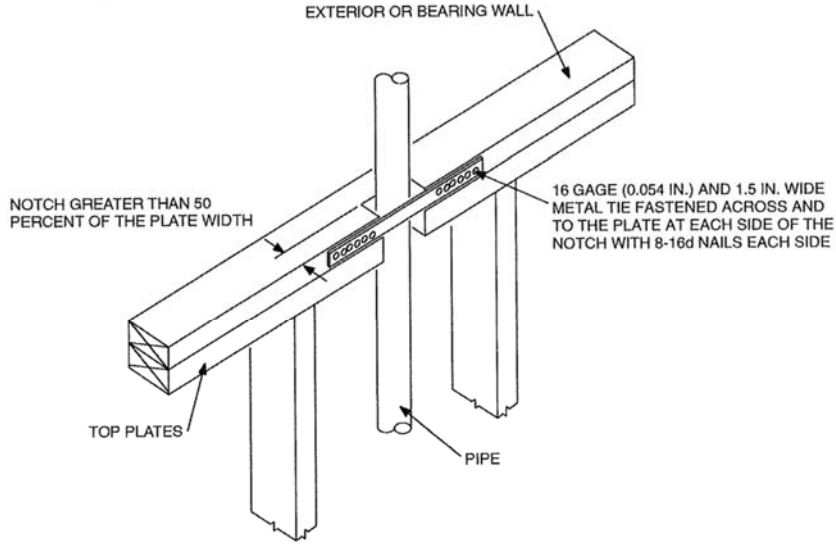

For SI: 1 inch = 25.4 mm.

**FIGURE R602.6.1**  
**TOP PLATE FRAMING TO ACCOMMODATE PIPING**

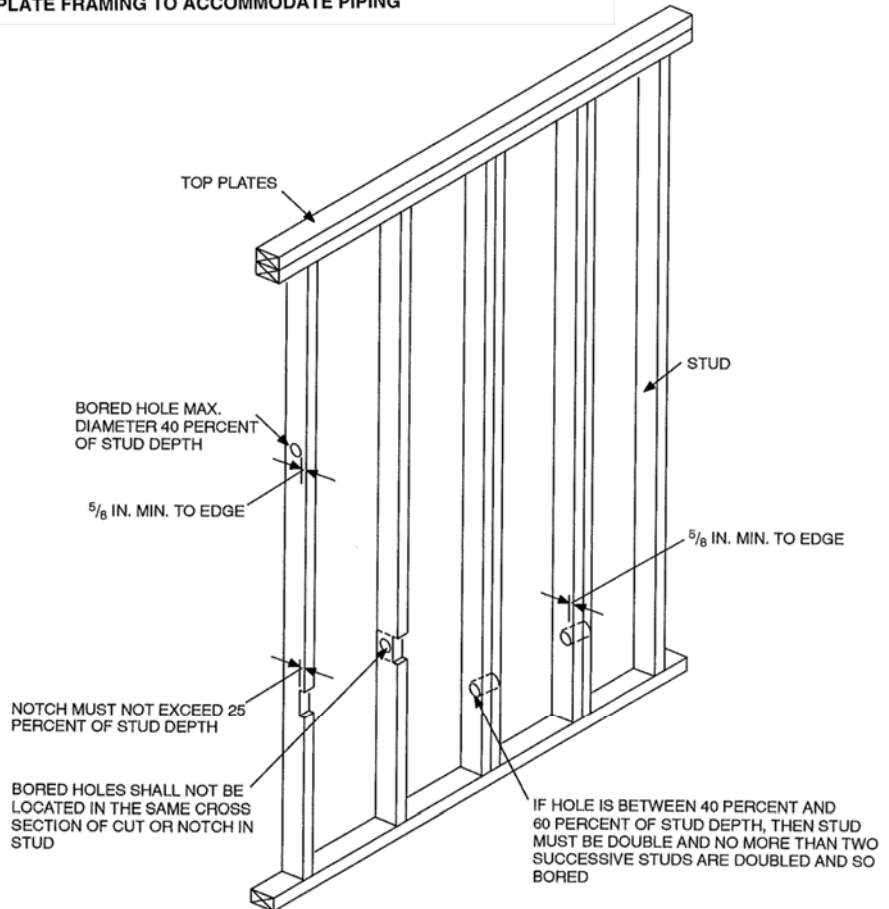

For SI: 1 inch = 25.4 mm.

**NOTE:** Condition for exterior and bearing walls.

**FIGURE R602.6(1)**  
**NOTCHING AND BORED HOLE LIMITATIONS FOR EXTERIOR WALLS AND BEARING WALLS**

**City of Seabrook**  
**Department of Community Development (Revised 2017)**

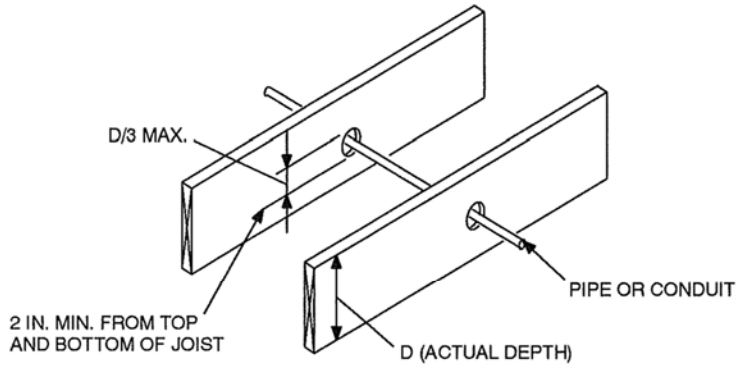

1 inch = 25.4 mm.

**FIGURE R502.8**  
**CUTTING, NOTCHING AND DRILLING**

